

Talentum[®] 16542

Flameproof (Exd) IR3 Flame Detector



Operation Manual

Thank you for using Flameproof (Exd) IR3 Flame Detector. When you are ready to use this product, please be sure to read this manual carefully. And follow the relevant operating steps provided, so that you can fully enjoy the services provided by our company, while avoiding damage to the machine or other accidents caused by your mis-operation. Please keep this manual properly so that you can consult and get help in time when you need it in the future.

User Service Guidelines:

- 1** Before using this product, please carefully check whether the accessories, product qualification certificate and user warranty card are complete according to the product factory list. If you find that they are incomplete, please contact the seller or manufacturer immediately.
- 2** Within twelve months from the date of sale of this product, if the user complies with the storage, transportation and use requirements, and the product quality is lower than the technical index, you can enjoy free maintenance with the warranty certificate.
- 3** Damages caused by violation of operating regulations and requirements, failures caused by maintenance by the special technical service department designated by our company, or product quality problems caused by irresistible factors, our company will carry out repairs for a fee.
- 4** When the product is being repaired, please take the initiative to show the product warranty card. Those who fail to show the product warranty card will be repaired for a fee.
- 5** After product maintenance and repair, please show this manual, and the maintenance personnel will fill in the attached "Maintenance and Repair Status Record" and sign; at the same time, please sign on the maintenance and repair status record of the maintenance personnel to confirm the maintenance and repair Content and put forward valuable opinions, if it is a unit user, please affix the official seal.
- 6** If you have any questions or dissatisfaction with the products and services we provide, including product technology, quality, installation and maintenance, service attitude, charging standards and other issues, please contact us in time, and we will properly handle your comments.

Warning:

It is strictly forbidden to open the cover of the detector at the work site.

- ∅ Before any operation, local regulations and on-site operation procedures must be followed.
- ∅ Any operation inside the detector must be performed by professional personnel.
- ∅ Please carefully check whether the wiring is correct before the instrument is powered on.
- ∅ The time interval between instrument power off and power on again is more than 5 seconds.
- ∅ The connecting devices and adding nodes must be powered off.
- ∅ The detector should use relatively independent power supply to avoid using the same power supply with large motor equipment.
- ∅ The shell of the detector shall not be damaged, otherwise the shielding effect will be affected.
- ∅ If the power input has no ground wire, the machine shall be safely grounded through the grounding terminal.
- ∅ Do not repair or disassemble the instrument by yourself.
- ∅ In the following work situation, be sure to disconnect the power supply before operation.
 - And protective cover must be used when exposed to open space.
 - 1. When the instrument terminal wiring and plug terminal;
 - 2. When connecting the ground wire.
- ∅ Do not install the instrument in the following situations:
 1. Where temperature and humidity exceed working conditions;
 2. Where there is a strong corrosive gas;
 3. Where there is a large amount of dust, salt and metal powder;
 4. Water, oil and chemical liquid are easy to sputter to the occasion;
 5. Where there is direct vibration or shock.

Contents

1 Overview

2 Main technical indicators

3 Schematic diagram of product structure

4 Installation

4.1 Installation position

4.2 Installation method

4.3 Installation principles

4.4 Installation area

4.5 Detection distance

4.6 Wiring precautions

5 Common faults and solutions

6 Matters needing attention

7 Warranty and maintenance

8 Storage

9 Accessories and others

1 Overview

Talentum® 16542 Flameproof (Exd) IR3 Flame detector is a 3 infrared flame detector produced by our company. This machine uses high-performance sensors (infrared wavelength 2.2µm/3.8µm/4.4µm/5.3µm, ultraviolet wavelength 185 ~ 260nm), infrared wavelength 4.4µm. The sensor has a high sensitivity to carbon dioxide generated by the combustion of hydrocarbons, and the ultraviolet sensor has a high sensitivity to the ultraviolet rays emitted by the flame. Other sensors filter the ambient light and surrounding heat radiation infection, which can better avoid the interference of the surrounding environment on the detection results. Microcontroller technology, combined with sophisticated SMD technology, has the advantages of good repeatability, temperature and humidity characteristics, long service life, and convenient operation.

The flame detector not only gives early warning of the burning flame of organic compounds, but also has good warning performance for the burning flame of inorganic substances. Suitable for oil refineries, petroleum pipelines, chemical plants, coking plants, oil depots, liquefied gas stations, CNG, LNG, wine warehouses, paint spray booths, drilling platforms, city fuel gas, boiler rooms, metallurgical industries, fireworks, Military industry, naval equipment, electric power industry and other places prone to liquid or gas fire, smokeless open flame and deflagration.

It is suitable for zone 1 and zone 2 containing IIA-IIB, explosive gas mixture places.

1.1 The design, manufacture and verification of this product comply with the following national standards:

GB3836.1-2010 "Explosive Atmosphere Part 1: General Requirements for Equipment"

GB3836.2-2010 "Explosive Atmosphere Part 2: Equipment Protected by Flameproof Enclosure "d""

GB15631-2008 Special fire detector

GB12791-2006 point type ultraviolet flame detector

GB/T 191-2008 Graphical signs for packaging, storage and transportation

1.2 The meaning of the explosion-proof mark

The explosion-proof mark refers to the mark used to describe the explosion-proof grade, temperature group, explosion-proof type and applicable area of explosion-proof electrical equipment.

For example: Ex d IIC T6 Gb (Flame-proof)

Ex	d	IIC	T6	Gb-	Equipment protection level
			-----		Temperature group
		-----			Class II explosion-proof category
	-----				Flame-proof type
-----					Explosion-proof mark

Ex--Explosion-proof general mark;

d--Flame-proof electrical equipment that can withstand the explosive pressure of the internal explosive gas mixture and prevent the internal explosion from propagating to the explosive mixture around the enclosure is marked "d";

The IIC explosion-proof group: Class II electrical equipment used in places other than mines;

T6--Temperature grade: T6 refers to the highest surface temperature of the equipment not exceeding 85 °C, which the security level higher;

Gb--equipment protection level: It has a high equipment protection level and will not explode under normal operation or expected failure.

1.3 Product model and code

The model and code of the detector are as follows: The model and code of the detector are as follows:

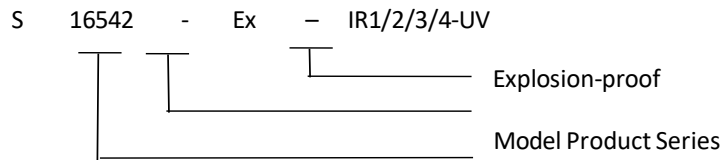

Product name	Product model	Code designation
Point infrared flame detector	16542 Exd-IR1/2/3/4	IR1: an infrared flame detector
		IR2: two infrared flame detector
		IR3 : three infrared flame detector
		IR4 : four infrared flame detector
	16542 Exd -UV	UV: ultraviolet flame detector
	16542 Exd -IR1/2/3/4-UV	Represents a composite flame detector

16542, S is the product form, 6xx is the serial number, and Ex is the general sign of explosion protection. As S16542 Exd-IR3, it represents two red and one purple composite spectrum flame detector.

2 Main technical indicators

Detection principle: IR/UV spectrum;

Wavelength range: Infrared 2.2μm, 3.8μm, 4.4μm, 5.3μm; UV 185~260nm; Sensitivity: Grade 1;

Response time: < 30s; Recovery time: < 30s;

Preheating time: 60s; Flame detection delay:

3s;

Ambient temperature: - 10 °C ~ 55 °C;

The maximum surface temperature of the shell shall not exceed 80 °C; Relative humidity: < 93% RH;

Explosion proof mode: flame-proof type; Explosion proof grade: Ex d IIC T6 Gb; Protection grade: IP66;

Power supply: DC24 V ± 10%;

Output signal: 1 group of switching value; Power consumption: ≤ 3W;

Cable used: ≥ 1.5mm² × 4;

Maximum distance between detector and host: $\leq 800\text{m}$; Weight: $\leq 1200\text{g}$;

Dimension: $145 \times 141 \times 113$ (mm); Pressure limit: $86\text{kpa} \sim$

106kpa ; Software version: v1.01

Place of use: it is used in dangerous places with class IIA \sim IIC of explosive combustible gas and temperature group T1 \sim T6.

3 Product structure diagram

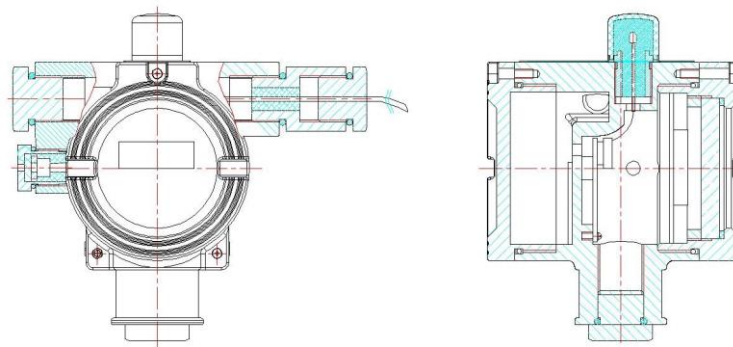

Figure 1

4 Installation

4.1 Installation location

1. Install the detector at twice the height of the highest target in the protection area. Within the effective range of the detector, it cannot be obstructed by obstacles, including transparent materials such as glass and other isolators. At the same time, it can cover all targets and areas that need to be protected, and it is convenient for regular maintenance.

2. When the detector is installed, it is generally tilted downward by 30-45 degrees, which can look down and forward, and reduce the possibility of mirror contamination. In order to avoid indirect incidence and reflection, it is necessary to keep a straight line incidence for all possible fires in the reserve.

3. In order to avoid the detection blind area, another flame detector is usually installed in the opposite corner. At the same time, it can provide backup when one of the flame detectors fails. Special attention: avoid possible false alarm sources within the cone detection range of the flame detector. The installation screw is not lose to prevent the detector from sinking under the influence of gravity for a long time, resulting in the change of detection area.

4.2 Installation method

The installation position without corrosive gas, oil fume and dust shall be selected at the detection site to avoid water immersion and water drenching. The method of fixation is as follows:

- 1) Fix the fixing bracket on the fixing surface with M6 expansion bolt.
- 2) Loosen the adjusting screw and adjust the detector to an appropriate angle, so that the cone-shaped range of the detector can cover the widest range and cover more areas that need to be protected.

4.3 Installation principles

- This detector must be installed, debugged, maintained and used by professionally trained personnel.
- When the detector is installed and wired, the monitored area should be within the effective range of the field of view.
- The installation of the detector should avoid obstacles as much as possible. For obstacles whose horizontal and vertical dimensions do not exceed 0.5 meters, the distance between the detector and the obstacle should not be less than 2.5 meters; when the external dimensions exceed 0.5 meters and cannot be avoided, the number of detectors should be increased appropriately.
- The connection state of the cable connection port sealing sleeve and each connection part must ensure its sealing effect and no water leakage.
- The detector shell must be grounded reliably to prevent interference from external radio frequency and electromagnetic noise.
- Ensure that the grounding point of each detector and the grounding point of the controller are connected to a reliable ground through the shielding layer, and it is forbidden for the detectors and controllers of the same system to be independently grounded at different places.
- It is forbidden to install the detector directly on the heat source or vibration source.

4.4 Installation area

The fire alarm that the detector can detect satisfies the inverse square law: if the distance of the detector is doubled, only 1/4 of the radiation may reach the detector. (As shown in Figure 3)

For example, an IR3 flame detector that can detect an ethanol fire of 0.1 square meters (33cmx33cm) at a distance of 17 meters, if installed at a detection distance of 34 meters, the minimum fire alarm needs to be 0.4 square meters. In contrast, within a range of 8.5 meters, only 0.025 square meters can trigger an alarm.

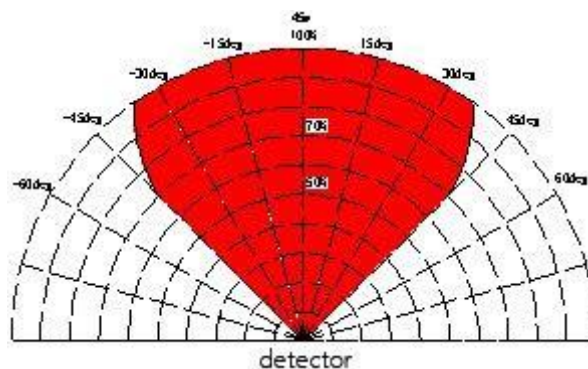

Figure 3-- Field view plan of infrared flame detector

4.5 Detection distance

The detection distance of the flame detector is related to the amount of flame radiation produced by different burning materials, the estimated flame size at the initial stage of the fire, and the absorption of part of the infrared radiation in the case of long distances.

- The national standard GB15631-2008 defines two standard test fires:

0.1 m² N-heptane plus 3% (volume percentage) Toluene fire 0.1m² Ethanol fire

● The national standard GB15631-2008 defines three sensitivity levels:

Detectors within the range of 0-25m must report fire alarm level 1
Detectors within 0-17m must report fire alarm level 2

Detectors within 0-12m must report fire alarm level 3

● The correction coefficients for the detection distance of different combustibles are as follows:

Combustible	Ethyl alcohol	Gasoline	Diesel	Kerosene (aviation oil)	Methyl alcohol	Crude oil	Acetone
Correction factor	1.0	1.5	0.8	1.0	0.8	1.0	1.5

For example, if gasoline is the combustible to be detected, the maximum detection distance is 1.5 times that of ethanol.

4.6 ⚠️ Warning precautions

After the detector is firmly fixed in the above installation position method, screw down the back cover of the detector, screw down the adapter wire counterclockwise, remove the explosion-proof gasket, put on the adapter wire and rubber sealing ring successively for the four core (selected according to the demand) transmission cable, and put them into the shell from the wiring hole. According to the explosion-proof requirements, do not take out the explosion-proof gasket in the unused wiring hole, and do not discard all parts on the detector shell and internal circuit board.

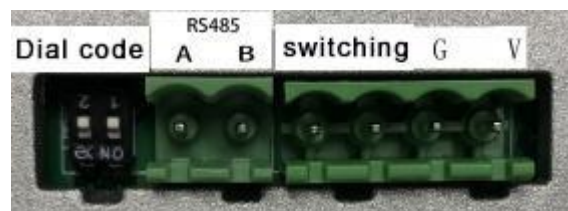

Figure 2

V	DC24V positive pole	RS485	Upload system
G	DC24V negative pole	Dial code	Adjust upload baud rate
Switching valve	Relay passive switch output		

The default baud rate is 2400, dial 1 to change to 4800, dial 2 to change to 9600, dial 1,2 to change to 19200.

After checking that the wiring is correct, draw out the redundant cable in the shell, and finally tighten the adapter wire to make the rubber sealing ring hold the cable tightly (explosion-proof design requirements). When using explosion-proof hose, it can also be directly connected with the machine.

The controller and detector shall be connected by four core cable with wire diameter not less than 1.5mm² (≤ 1000m).

After checking the connection of each link, screw up the back cover and screw on the fixing screw. According to the user's site conditions, the cable can be connected first, and then the detector can be fixed.

5 Common faults and solutions

Fault phenomenon	Cause of issue	Processing method
Light does not shine	Poor connection of power cord	Check whether the power cord is connected firmly and the voltage is normal
	The power cord is reversed	Connect the power supply properly
No alarm in case of flame	Irradiation angle is wrong	Adjust the installation angle of the detector
	Circuit failure	Factory repair
Abnormal connection with controller	Wiring failure	Check the line
	Circuit failure	Factory repair

6 Matters needing attention

6.1 This machine should be used in a place where there is no corrosive gas, oily smoke, dust and rain, to prevent it from falling from a height or being subjected to severe vibration.

6.2 There must be no large particles of vapor such as liquid vapor that cause light scattering at the probe, otherwise it will affect the test results.

6.3 There should be no medium with high concentration of smoke and fog lamps that affect light transmission in the monitoring area, otherwise it will affect the detection sensitivity of the detector.

6.4 This machine has been inspected and tested before leaving the factory. In order to ensure the accuracy of detection, flame tests should be carried out regularly to ensure that the performance of the detector can be understood in time, and problems can be found and resolved in time.

6.5 Please remove the battery when the remote control is not in use to increase the service life and avoid the impact of battery leakage on the remote control.

6.6 The products that have obtained the explosion-proof certificate are not allowed to randomly replace or modify the components or structures that affect the explosion-proof performance.

6.7 Precautions for explosion protection

1) The explosion-proof mark refers to the mark used to describe the explosion-proof grade, temperature group, explosion-proof form and applicable area of explosion-proof electrical equipment.

2) In the corresponding national policies and standards, there are clear regulations on the electrical design selection, installation or use of explosive hazardous locations, and the installation or use is strictly in accordance with the national standards.

* **The grounding must be safe and reliable.**

* **It is strictly forbidden to open the cover when power is on.**

* **If the sealing ring and fastener are damaged, they should be replaced in time.**

* **The mounting screws are tightened and not loosened to prevent the detector from sinking under the influence of gravity for a long time, causing the detection area to change.**

- * During maintenance, pay attention to protect the explosion-proof surfaces, and all explosion-proof surfaces must not be damaged or rusted.
- * The length of the reserved cable is greater than 1 meter. During installation and use, the free end of the cable should be connected to the explosion-proof junction box or equipment on the site.
- * Units should strictly abide by these regulations to ensure the safety and explosion-proof of electrical equipment in explosive hazardous locations.

7 Warranty and maintenance

1) This product has a one-year warranty period. If there is a failure in normal use, you can enjoy free factory repair and maintenance services. Damages caused by man-made and natural disasters and abnormal use are not covered by the warranty.

2) If the detector fails, contact our company in time, and our company will provide a solution as soon as possible based on the on-site situation.

3) If the user cannot eliminate the fault, the detector can be sent back to our company for repair, and we will eliminate the fault as quickly as possible and return it to the user.

8 Storage

The detector should be stored in a ventilated room where the ambient temperature is $-10^{\circ}\text{C}\sim 55^{\circ}\text{C}$ and the relative humidity is not more than 85%RH, and the air must not contain harmful gases or impurities that can corrode the detector.

9 Accessories and others

9.1 Accessories

The matching detector provides a paper box, a flame detector, a set of detector mounting brackets, a manual, and a certificate of warranty card.

9.2 Other

The detectors are inspected and qualified before leaving the factory, and a certificate is issued. If damage occurs during transportation, the manufacturer is responsible for replacement.

